

# AN INTERMITTENT-ACTION CAMERA WITH ABSOLUTE TIME CALIBRATION

G. Hefley, R. H. Doherty and E. L. Berger  
National Bureau of Standards  
Boulder Laboratories  
Boulder, Colorado

## Summary

The Central Radio Propagation Laboratory of the National Bureau of Standards, Boulder Laboratories, has developed a recording system which will simultaneously photograph randomly occurring events and the precise time of each event (Fig. 1). The system employs a camera which has a minimum consumption of film but can complete a framing cycle in seven milliseconds. The timing system is capable of resolving time to within a few microseconds. When the standard time broadcasts of WWV are used to synchronize the system, the absolute accuracy is dependent upon the propagation variables of the WWV signal.

The high framing rate of the camera results from the use of a unique clutch system between the film drive and a continuously revolving flywheel. The clutch actuation mechanism is similar to a large electrodynamic speaker.

When a pulse is applied to a part corresponding to the voice coil, a cone is driven into engagement with the flywheel, thus rotating a small drum in contact with the film. The rotation of the drum pulls one frame of film past the lens opening. The peak power applied to the voice coil is approximately 35 kw. Power surges of this magnitude may be repeated at intervals of only a few milliseconds by utilizing two condenser reservoirs and two thyratrons in a series arrangement. An 88-microfarad condenser is discharged through the voice coil by one thyatron and after a short delay is recharged from a 1600 microfarad reservoir by the other thyatron. Consequently, the power supply required to operate the system need only to provide an average current sufficient to maintain the charge on the large condenser reservoir at the maximum duty cycle.

The timer is composed of conventional decimal-counting units arranged to count from ten microseconds to thirty-one days with the count controlled by a precision 100-kilocycle standard. Each of the decimal-counting units has a 1-2-2-4 binary output, all of which are read out in parallel by the same pulse used to trigger the camera. To prevent any ambiguity in the read-out due to the binary output changing state, the time of the read-out is controlled by the timer. The read-out is made by the first 100-microsecond pulse following the event to be recorded.

Time is displayed for photographic purposes by use of small neon bulbs which are illuminated by a pulse of 100-microsecond duration. Since this pulse is 100-microseconds long, smaller increments of time must be resolved by another means such as time markers on an oscilloscope trace.

## Introduction

Studies of intermittent, randomly occurring events such as the electromagnetic radiation from lightning strokes require recording instruments of a special type. Because of the excessive film consumption it is impractical to take photographic records of oscilloscope waveforms for long periods of time with strip cameras. Commercially available framing cameras do not attain framing rates great

CAMERA AND TIMER

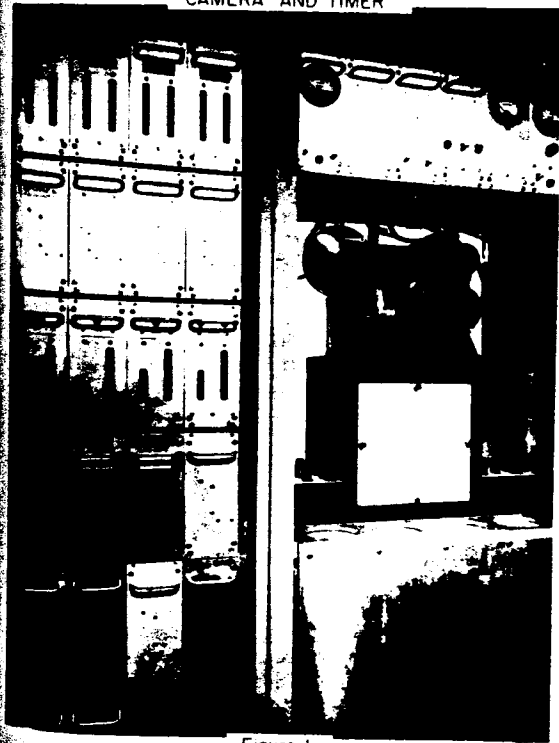

Figure 1

enough for certain sferic observations. Frequently, it is necessary to combine the data with some form of accurate time presentation. For example, 1) sferics observed at widely separated stations can be identified on a world time basis; and 2) for precise measurement of the time interval between sferics.

A device which appears to satisfy these requirements has been developed at the National Bureau of Standards, Boulder Laboratories, Boulder, Colorado. Although it was designed and built primarily for sferic studies, the basic concepts and certain features of this instrument may be useful in other research and practical applications. (Fig. 2).

### FUNCTIONAL SYSTEM DIAGRAM

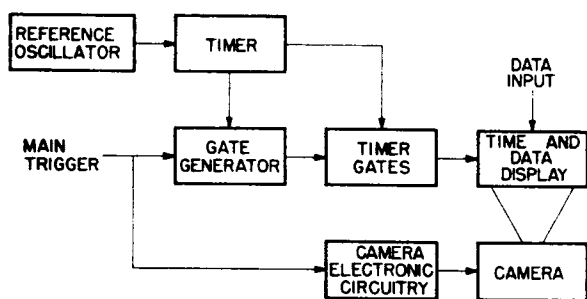

Figure 2

#### Design Approach

It is assumed that an electronic trigger can be derived from the data to be recorded. The time at which the trigger occurs for the purposes of this report is considered to be the time of the event. This trigger and other triggers derived from it in fixed time relationships initiate the oscilloscope sweeps for the data presentation and provide the commands for the time read-out and the mechanical functions of the camera proper.

Sixteen mm. film was chosen as a practical compromise between two mutually opposing considerations. Larger film would have been more desirable from the standpoint of picture quality or resolution but would have required greater torque to accelerate both it and the larger transport mechanism.

At the time the design was undertaken a film transport time of about five milliseconds was considered adequate for the application at hand. In most cases, oscilloscope sweeps of 500 to 1000  $\mu$ sec were used for data presentation. The objective was, therefore, to build a camera that would complete an operational cycle in about six milliseconds. It was further required that the camera be able to cycle at this rate for a

number of frames.

In this application the average cycling rate was relatively low so there was no unusual requirement for a large driving motor. The essence of the mechanical problem was to supply the high instantaneous torques necessary to accelerate and decelerate the film and especially the film transport mechanism in the short period of time required.

The peak vs. average power requirements were met by the simple expedient of an appropriate flywheel mounted directly on the motor shaft. The more difficult part of the problem was to transmit the available high peak power to the film in a reliable and uniform manner.

The type of mechanism which would be ideal would combine some of the characteristics of both a friction and a positive action clutch. That is, a clutch which would engage and disengage smoothly and quickly with a minimum of external force and at the same time be capable of transmitting a very high torque.

The type of device selected was essentially a cone clutch with the engaging surface operating just outside the critical angle.

The command signal available to actuate the camera (which was supplied by other equipment) was two microseconds in duration with a nominal amplitude of 100 volts. A transducer was required to cause this signal to engage the clutch for the period of time necessary to advance the film one frame. The principle used to accomplish this was to cause a fixed quantity of electricity to flow in a coil similar to the voice coil in a dynamic speaker upon receipt of each command signal. The movement of the voice coil was used directly to engage the clutch.

The use of the usual sprocket wheel to advance the film was not considered because of excessive point pressures exerted on the film by the large accelerating forces. Instead, it was decided to apply the accelerating force across the entire width of the film by means of a precision neoprene-surfaced cylindrical roller.

It was evident from the outset that the inertia of the intermittently moving parts would be of major importance. The design of the driven parts to minimize inertia and yet provide the necessary mechanical strength was rather straightforward. Managing the film supply, however, in such a manner that excessive inertial loads would be prevented was a separate problem of at least equal importance. In the design requirements it was estimated that the camera should be able to take at least twenty frames in rapid succession. It seemed totally impractical to draw film directly from the supply magazine at such high intermittent speeds because of the generally complicated mechanism involved and the possibility of film breakage. Accordingly, it was decided to provide and maintain a free and

supply  
and the  
On  
quire  
in this  
unblan  
data o  
A  
synch  
choser  
to rec  
instan  
out sc  
city e  
hundr  
in a c  
small  
displa  
T  
contro  
of the  
accur  
two g  
accur  
(and c  
trans  
propa  
at dis  
one n  
and is

unsupported loop of film between the drive roller and the supply magazine.

One simplifying aspect of the design requirements was that no shutter was required. In this case, the cathode ray tubes were simply unblanked and the time was read out when the data occurred.

A crystal-controlled timer which could be synchronized with standard time signals was chosen to maintain a time reference. In order to record the time of an event on the film an instantaneous and unambiguous parallel read-out scheme was devised. For circuit simplicity each increment of time greater than two hundred microseconds was displayed on the film in a coded binary form. Increments of time smaller than two hundred microseconds were displayed on the oscilloscope traces.

The relative time accuracy of a crystal-controlled timer is dependent on the stability of the crystal; whereas, the absolute time accuracy or the time comparison between any two geographical points is dependent on the accuracy of the synchronizing signal. WWV (and certain other standard time broadcasts) transmit world time accurately, but due to the propagation path, instantaneous measurements at distant locations can only be resolved to about one millisecond. Through arduous investigation and interpretation of available ionospheric data

WWV time can probably be established in retrospect to within two or three tenths of a millisecond.

A low-frequency navigation system known as Loran C transmits signals that may be received in excess of one thousand miles with a stability of one to two microseconds. If these signals were available at all locations and if they were properly synchronized with each other and with a world time standard, absolute time would be available with an accuracy of one to two microseconds.

The timer described in this report could be synchronized with Loran C signals to provide microsecond absolute timing.

### System Description

#### Camera Mechanics

The camera that was developed, based on the indicated design approach, utilizes methods for film storage and transfer that are rather unique and require detailed explanations. In addition to the film storage and transfer systems, the optical portion of the camera is a Dallmeyer, 16 mm. wide-angle f1.5 lens, mounted in a vertical plane for direct exposure.

The main drive unit (Fig. 3) consists of a 3600-rpm induction drive motor, the flywheel,

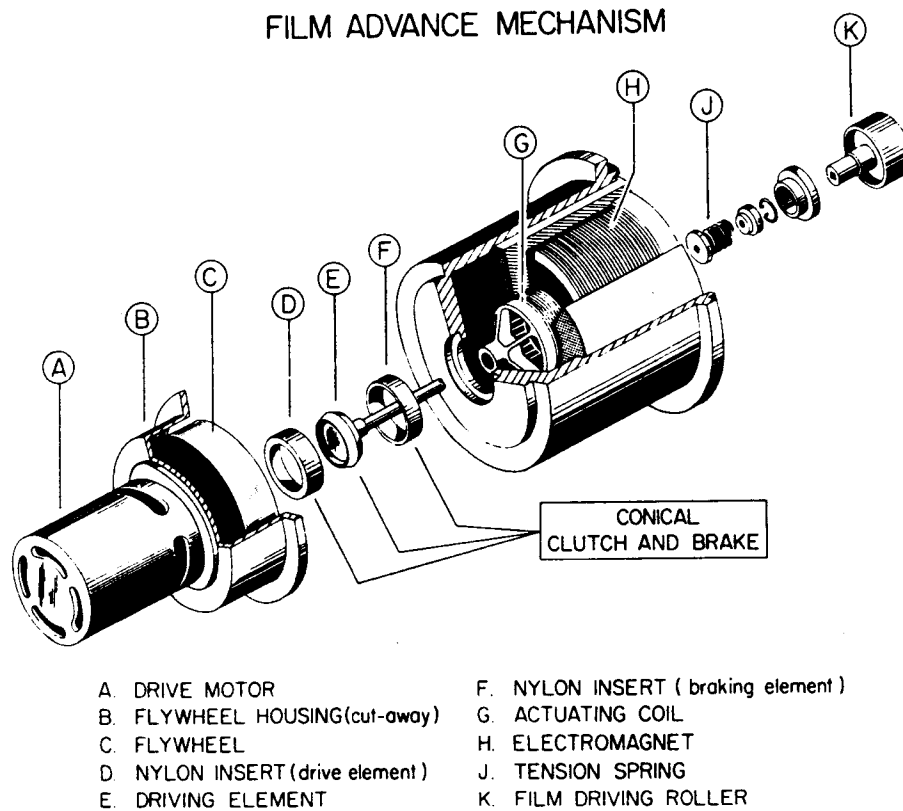

Figure 3

a conical clutch and brake, film drive rollers and the triggering mechanism. Mounted directly on the motor is a flywheel with a nylon insert used as the driving element in the clutch brake system. The driven element, in normal position, is spring loaded against a stationary, identical nylon insert which acts as the braking element. The mechanical triggering mechanism consists of a large electromagnet and a freely suspended coil. In principle, it is entirely similar to a large electrodynamic speaker. When current is applied to the coil an axial thrust is exerted on the driven element, thus engaging it with the nylon insert (driving element) in the flywheel. The clutch and brake elements are tapered to form sections of a cone and the angle of this taper is close to the critical angle of the cone of friction. In this way, maximum frictional drive and braking are obtained without wedging of the components.

The kinetic energy stored in the flywheel provides the high instantaneous torque necessary to accelerate the transport mechanism when the clutch is engaged. The maximum duty cycle of the film advance is affected by the size of this flywheel since it must store sufficient energy so that the motor speed will not be significantly reduced during the maximum operating rate.

The mechanism for engaging the clutch is a freely suspended coil of insulated copper wire wound on a three-inch diameter aluminum shell and centered in the air gap of the electromagnet. This coil is connected to the shaft of the driven element of the clutch in such a way that the shaft may rotate inside the coil, but the axial movement of the coil is transmitted to the shaft. The force exerted by this coil is proportional to flux density, wire length and the current. The time during which the force is applied depends on the length of time the current flows; thus, the film advance is controlled by varying the period of time during which the current flows through the coil.

The film transport mechanism consists of the film drive roller and a tension roller (Fig. 4).

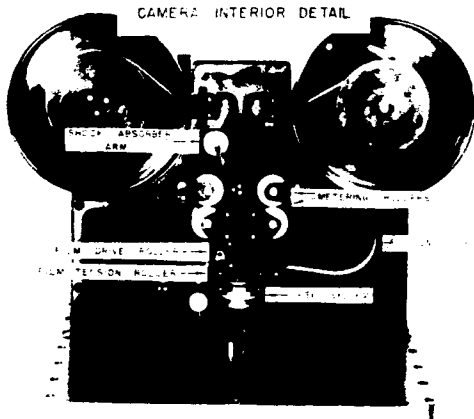

Figure 4

The film drive roller is neoprene-coated and has a spline which engages with the shaft of the driven element of the clutch. The shaft is free to move axially but rotational motion is transmitted to the roller. The tension roller is spring loaded against the drive roller with provisions for release to facilitate film loading.

The film storage mechanism contains a 200-ft supply and a 100-ft take-up magazine with a spring loaded light trap that operates when the magazines are removed from the camera. The take-up tension is applied by operating a small, heavy-duty motor (Fig. 5) at low voltage in a stalled condition.

CAMERA EXTERIOR DETAIL



Figure 5

This motor is located directly behind the take-up magazine and is connected to the film spool inside this magazine. A set of metering rollers (Fig. 4) maintain a loop of film to keep the shock of acceleration from tearing the film and to reduce the amount of mass that the main-drive roller must move. These metering rollers are geared together in such a manner that, as film is pulled into the take-up magazine, an equal amount of film is removed from the supply magazine to keep a constant loop of film ahead of the drive roller.

#### Camera Electronics

The electronic circuitry for the camera is designed to deliver high current for short durations and at rapid intervals (Fig. 6 -a). A large condenser reservoir supplies this high current intermittently and thus reduces current which must be drawn from a power supply to an average value sufficient to sustain the average pulse rate. The reservoir presently used is a 1600-microfarad condenser which will provide approximately ten advances at maximum speed. The power supply is capable of delivering 275 milliamperes which will support an average rate of 60 frames per second. The average rate could be increased by using a larger power supply and the number of adjacent advances could be increased by increasing the 1600-microfarad

res  
dis  
GL  
The  
the  
  
TRIG  
INPUT  
  
+  
VI  
  
tri  
ch  
and  
is  
de  
sa  
ch  
co  
(F  
  
the  
me  
cl  
a  
tri  
  
Ti  
  
an  
us  
the  
de  
co  
se  
th  
te  
ad  
si  
ac  
lir  
sy  
if

reservoir. The camera drive is actuated by discharging an 88-microfarad condenser with a GL-5544 thyatron through the "voice" coil. The 88-microfarad condenser is recharged from the large reservoir by use of a second GL-5544.

### CAMERA ELECTRONIC CIRCUITRY

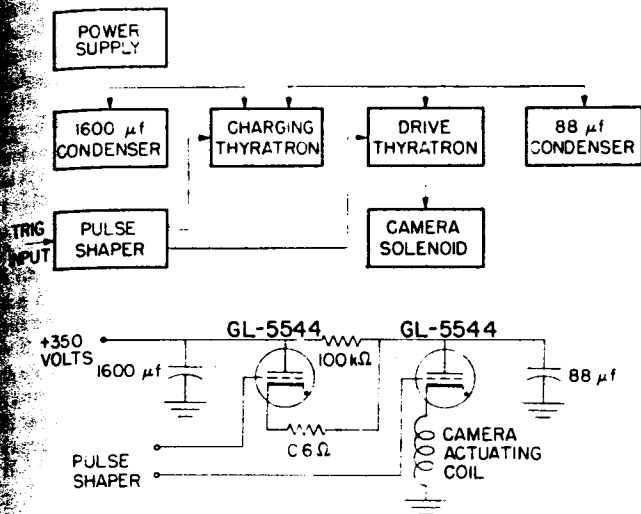

Figure 6

The basic scheme is as follows: A main trigger pulse is applied to a thyatron trigger chassis. A 40-microsecond pulse is generated and fed to the drive thyatron through an isolation transformer. The main trigger is also delayed two milliseconds and then used in the same way to fire the charging thyatron. The charging thyatron recharges the 88-microfarad condenser from the 1600-microfarad reservoir (Fig. 6 -b).

The complete electronic cycle requires less than five milliseconds and since the film is moving for five milliseconds, triggers spaced closer than this would be useless. Therefore, a "killer" circuit was included to eliminate triggers spaced closer than five milliseconds.

### Timer Electronics

A reference oscillator operating at 100 kc and with a stability of one part in  $10^8$ /day is used to control the timer. Pulses derived from the oscillator output are fed into a series of decimal-counting units so arranged that the count will correspond to time from microseconds to days. The resolution accuracy of this system is two or three microseconds and the time between any two spheres can be determined within this accuracy. The timer is adjusted by utilizing the WWV standard time signals. Therefore, the absolute time accuracy to which the timer is calibrated is limited by the propagation variables. This system could be synchronized more accurately if more precise time signals were available.

The timer count from ten microseconds to ten seconds is accomplished by using standard decimal-counting units. Between each unit other stages were added to provide amplification, clipping, differentiation, and to isolate the output of one unit from the input to the next unit. The use of these stages in addition to cathode followers between the units permits longer leads for physical separation of the units. The limiting and isolation provide quite effective protection against spurious signal pick-up.

The count of six necessary for the seconds and minutes counters is accomplished by removing the output circuits from the fourth binary digit and installing a voltage divider circuit in its place. The hours counter is arranged so that it will reset with an output pulse at 24 (Fig. 7).

### HOURS COUNTER MODIFICATION

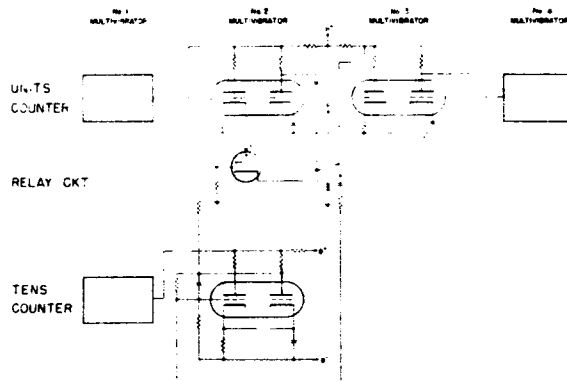

Figure 7

This is accomplished by actuating a relay when the tens-of-hours counter reaches the count of two. When this relay is energized the normal circuit in the units of hours counter is modified in that the output from the second binary digit at count of four is not fed to the third binary digit, therefore, this counter returns to zero rather than counting to five. The output of this second binary digit is applied to the second binary digit in the tens-of-hours counter, thus resetting it to zero and providing an output pulse to the days counters.

### Timer Calibration

Dual inputs to the minutes, hours and days counters facilitate resetting the counters after non-operating periods. One-second pulses can be supplied to all of these counters through the other input for setting purposes. A push-button switch on the front of each unit allows the minutes, hours, or days counters to be reset within the elapsed time of 60, 24, or 40 seconds, respectively. The input to the seconds counter can be interrupted by a switch, holding that counter and hence all subsequent counters.

Stopping the seconds counter at 00 and starting it again with the five minute tone from WWV completes the calibration to within one second.

The procedure necessary to calibrate the timer more precisely is to trigger an oscilloscope with the one-second pulses and to display the WWV signal on this oscilloscope (Fig. 8).

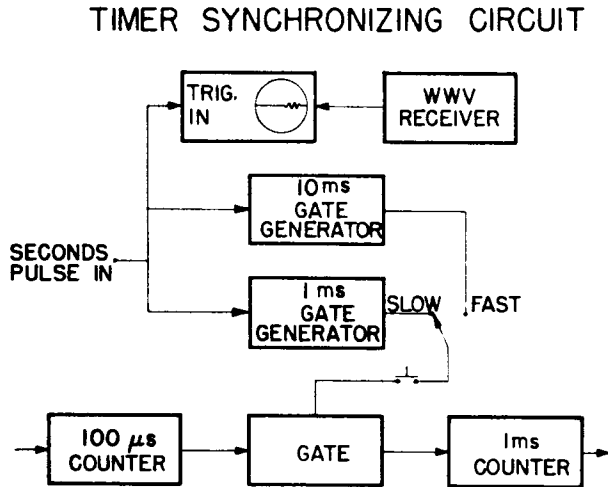

Figure 8

If the one-second pulses are systematically slowed down, the WWV seconds pulses will appear to move from right to left across an oscilloscope with a normal sweep. To slow down the timer, two gate generators are also triggered with the one-second pulses and these gates are used to remove pulses at the input to the one millisecond counter. In the fast position ten pulses are removed, slowing the timer ten milliseconds; in the slow position one pulse is removed, slowing it one millisecond. This allows the timer to be set within one millisecond of WWV. If a more accurate setting were desired, the pulses could be removed at the input to the 100-microsecond counter and a third gate with a duration between 100 microseconds and one millisecond could be used.

Timer Read-Out

The decimal-counting units have a modified binary read-out code. This code is the 1-2-2-4 code consistent with the binary states associated with the feedback loops required to obtain a count of ten rather than a count of sixteen.

The output of each binary digit is fed to a logical "and" circuit which operates a neon bulb in the camera field when an additional gate input is applied. This gate input is initiated by the main trigger, but controlled by the timer in such

a way that all binary digits are read out in a stable state, thus precluding ambiguity. Fig. 9 shows the block diagram and the waveforms associated with the gate generator used to produce the gate for all of the "and" circuits.

100 MICROSECOND GATE GENERATOR

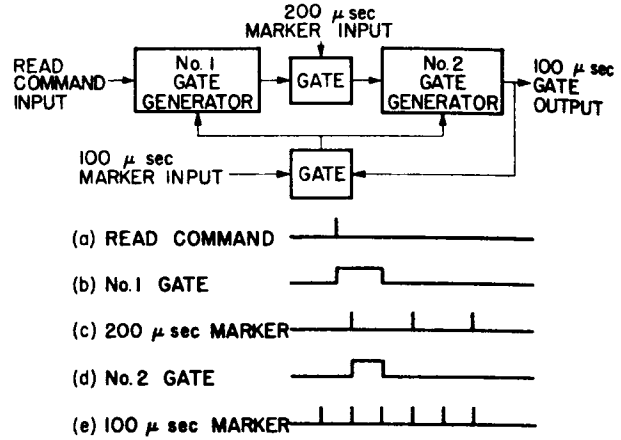

Figure 9

The read command (Fig. 9 -a) is applied to a gate generator. The generated gate (Fig. 9 -b) passes the first 200-microsecond pulse (Fig. 9 -c). This pulse generates a second gate (Fig. 9 -d) which is stopped simultaneously with the first gate (Fig. 9 -b). Both gates terminate with the next 100-microsecond pulse (Fig. 9 -e). The 100-microsecond gate (Fig. 9 -d) thus formed is the gate generator output which is one of the inputs to the "and" circuit. This gate occurs only when all of the binary counters above 200 microseconds are in a stable state.

The neon bulbs displaying the binary counts are arranged in sets of four for convenience in transposing to decimal numbers. The time below 200 microseconds is resolved on the oscilloscope trace since ten and 200-microsecond markers are superimposed on the traces (Fig. 10). If traces of less than 200-microseconds duration were desired, time could be read out on neon bulbs down to ten microseconds by utilizing circuitry to hold the binary digits between ten and 200 microseconds.

System Performance and Results

Extensive operation of the camera and timer during a four-month period demonstrated the system's usefulness and also indicated where modifications would be warranted.

The direction that the film moved was parallel to the oscilloscope sweep direction (Fig. 11). Sferics which occurred at time intervals less than five milliseconds would

overlap and the traces would be lengthened. Rotation of the camera or the scope traces by 90° would resolve this problem. Movement of the film transversely to the direction of the trace should allow sferics separated by only one millisecond to be resolved.

The time measured from the main trigger until the camera advance is complete is seven milliseconds. The film motion is about 24 mm. or one and one-half 16 mm. frames. The calculated time necessary to move the film 24 mm. with the one-inch drive roller operating at 3600 rpm is 5.2 milliseconds. The interval measured between the main trigger and the start of the film advance is 1.5 milliseconds, so evidently when the film is moving it is moving at nearly maximum velocity. Fig. 11 shows two frames nine milliseconds apart and two others with closer spacing (4.5 milliseconds) where the film was moving when the second sferic occurred. It can be seen that if sferics occur with spacings greater than seven milliseconds the camera is an intermittent-action frame camera, whereas, if the sferics are more closely spaced the camera becomes a strip camera at a speed of 178 inches per second for short durations. It is obvious that main

triggers occurring more often than five milliseconds would be meaningless and, therefore, a blocking circuit is operated for five milliseconds following each main trigger.

Present limitations on the maximum film velocity are the motor speed and the drive roller diameter. Increasing the motor speed creates bearing problems due to the heavy fly-wheel and shock loading. On the other hand, increasing the drive roller diameter from one inch to three or four inches appears entirely feasible. This change would reduce the film transport time from 5.2 milliseconds to 1.7 or 1.3 milliseconds.

Experiments have been conducted using an aluminum disk and a coil wound with strip copper to determine the applicability of the induction disk to engage the clutch. Initial results indicate that this method may be faster, thus reducing the 1.5 millisecond start time, but the disk will not keep the clutch engaged for an extended period of time as can be done with the voice coil. The mechanism associated with the induction disk has fewer moving parts and is inherently simpler. This method should be rather excellent for higher film transport speeds.

### CAMERA FIELD PRESENTATION

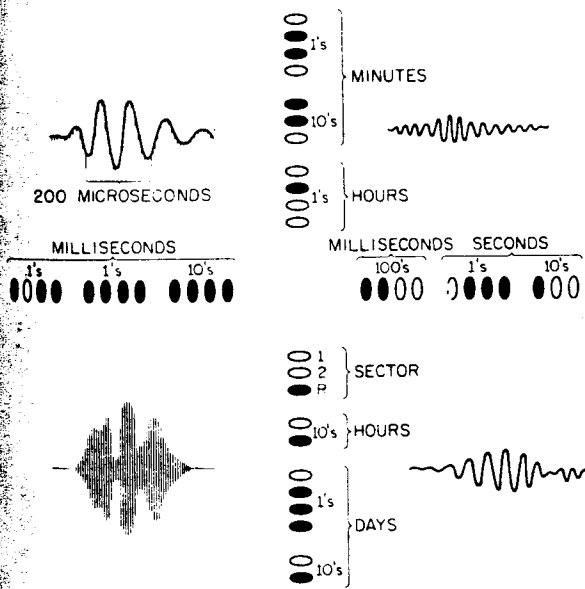

Figure 10

### PHOTOGRAPHS OF ADJACENT FRAMES

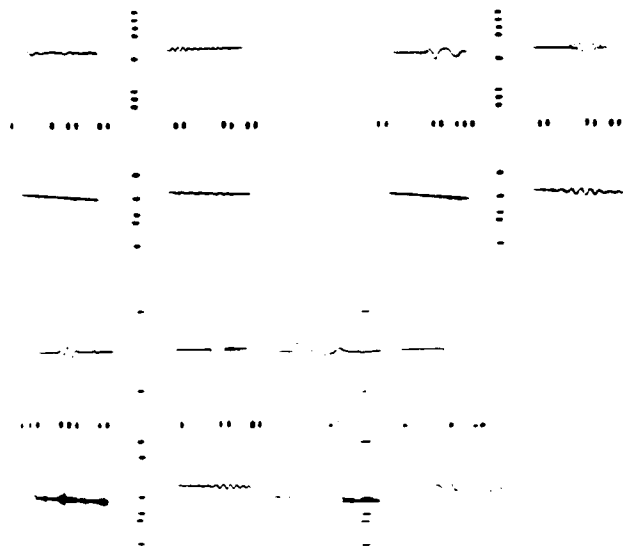

Figure 11