

High sensitivity detection of molecular oxygen using cavity-enhanced frequency modulation spectroscopy

L. Gianfrani¹, R. W. Fox, and L. Hollberg

National Institute of Standards and Technology
325 Broadway, Boulder, Colorado 80303-3328, USA

¹ Dipartimento di Scienze Ambientali della Seconda Università di Napoli
Via Arena, 22, I-81100, Caserta, Italy

In recent years, high finesse optical cavities have been used for high sensitivity spectroscopy by exploiting the very long absorption path lengths, 10 to 100 times greater than in traditional multipass cells. Cavity Ring Down Spectroscopy applications have been widely performed with both pulsed [1] and CW laser sources [2]. Direct absorption spectroscopy with an optical cavity has also been demonstrated by recording the peak transmitted power around an absorption line [3]. Another relevant application is represented by saturated absorption spectroscopy of overtone molecular transitions. In this case, high finesse and high build-up provide enough intracavity power for saturation of the absorbing gas [4]. More recently, the "NICE-OHMS" method, using frequency modulation techniques, has been used to detect extremely weak saturated signals in a high finesse cavity [5]. In this novel method, the laser beam is frequency modulated at exactly the cavity free-spectral-range (FSR) frequency. Using heterodyne detection of the transmitted power, the phase shift of the central carrier produced by optical dispersion gives rise to the signal. The NICE-OHMS method has reported detection sensitivities for absorption of 10^{-12}cm^{-1} [5]. In this work, we demonstrate how the cavity enhanced frequency modulation technique can be used to perform high sensitivity measurements of small absorption signals, corresponding to weak absorption lines in molecular oxygen.

The experimental setup is shown in figure 1. A single-mode diode laser emitting at a wavelength of 774 nm at room temperature was employed. It was antireflection coated and mounted in a Littman external cavity configuration. The laser wavelength could be tuned down to 762 nm and a sub-MHz narrowing of the laser emission was accomplished. The laser wavelength was measured by means of a 7-digit Michelson wave-meter. An asymmetric optical cavity was used, with a flat input coupler and 1-m radius of curvature output mirror. The cavity length was 26 cm and could be changed by means of a pzt on the output mirror. The cavity was mounted in a stainless steel vacuum chamber into which a sample gas could be introduced. In the present measurements, we typically changed the pressure between few mTorr up to 1 Torr ($\sim 0.1 - 130$ Pa). The cavity linewidth was measured to be 140 kHz, which corresponds to a cavity finesse of about 4100. The laser frequency was locked to the cavity resonance with the Pound-Drever-Hall method, using sidebands at 8 MHz produced by an electro-optical modulator (EOM1). Phase sensitive detection of the cavity reflected beam provided an error signal that was used to control both the laser injection current and external cavity length. The maximum frequency scan with the laser locked to the cavity was 2 GHz, limited only by the piezo on the cavity. This scan was large enough to allow recordings of the whole absorption profile. Implementation of the NICE-OHMS method, with phase modulation at the cavity FSR frequency (570 MHz), was performed using another electro-optical modulator (EOM2). The transmitted beam was detected by a fast photodiode.

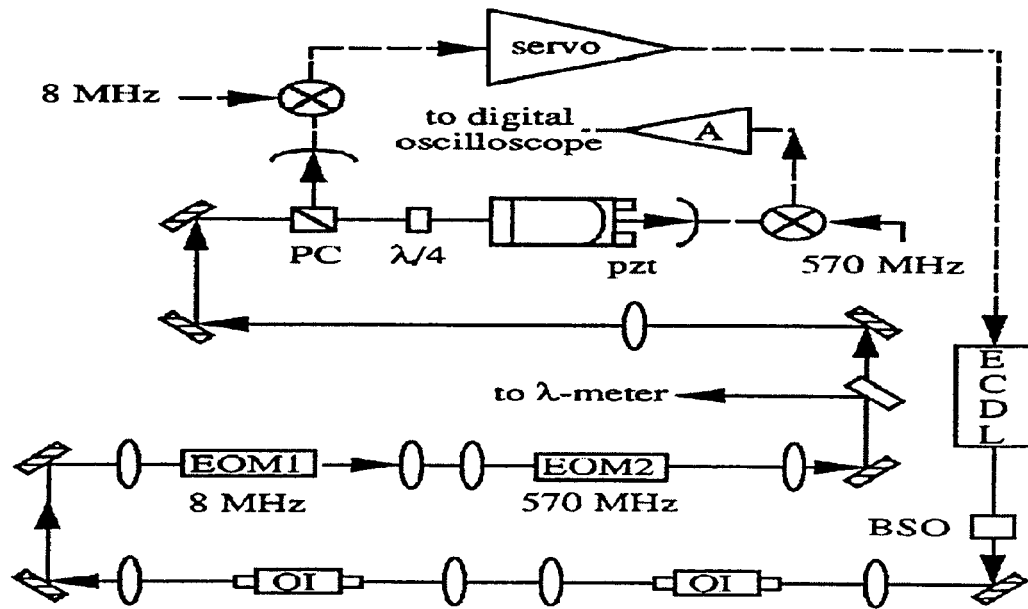

Fig. 1. Experimental setup. ECDL stands for extended cavity diode laser, BSO beam shaping optics, OI optical isolator, EOM electro-optical modulator, PC polarizing cube beam splitter, A current preamplifier.

Weak magnetic dipole transitions of the oxygen $b^1\Sigma_g^+ (v'=0) \leftarrow X^3\Sigma_g^- (v''=0)$ band around 762 nm were observed. Absorption profiles could be easily recorded by detecting the transmitted power during continuous scans of the cavity length. The transmitted power P_t is given by:

$$P_t = P_{in} \frac{t_1^2 t_2^2}{(1 - r_1 r_2)^2} \frac{1}{\left(1 + \frac{\sigma}{\pi} p L F\right)^2}$$

Here P_{in} is the incident power, σ the absorption cross section, p the oxygen pressure, F the empty cavity finesse, L the cavity length, and t_1 , t_2 , r_1 , and r_2 are the amplitude transmission and amplitude reflection coefficients of the cavity mirrors. When the molecular absorption is small compared to the empty cavity loss, the total fractional change in the transmitted power can be written as:

$$\frac{\delta P_t}{P_t} = \sigma p \frac{2}{\pi} F L.$$

This means that the absorption pathlength is enhanced by a factor $F/2\pi$. Hence, an equivalent absorption length L_{eq} can be defined as equal to $F L / 2\pi$.

We measured, for the $^1P(9)$ line at 763.843 nm, the absorption for several values of the oxygen pressure. Using the equation above and considering that the absorption cross section for the $^1P(9)$ line is $\sigma = 7 \cdot 10^{-6} \text{ cm}^2 \text{ Torr}^{-1}$ ($5 \cdot 10^{-8} \text{ cm}^2 \text{ Pa}^{-1}$), we found a value for L_{eq} of 680 (30) m, in agreement with the value deduced from the measured empty cavity finesse.

An example of the heterodyne detection of an O₂ absorption signal is shown in figure 2. The oxygen pressure was 35 mTorr (4.7 Pa), which gives a single pass absorption of $6 \cdot 10^{-4}$. For the same experimental conditions (detection bandwidth $\Delta f = 10$ Hz), the noise spectrum for the output

signal was measured. The signal to noise ratio was about 500, so the minimum detectable single-pass absorption was about 10^{-8} . Detection of $^{16}\text{O}^{18}\text{O}$ was also performed, in a natural abundance oxygen sample. In the presence of few Torr of oxygen, we observed the Q(11) line at 763.928 nm, with a signal to noise ratio of about 100.

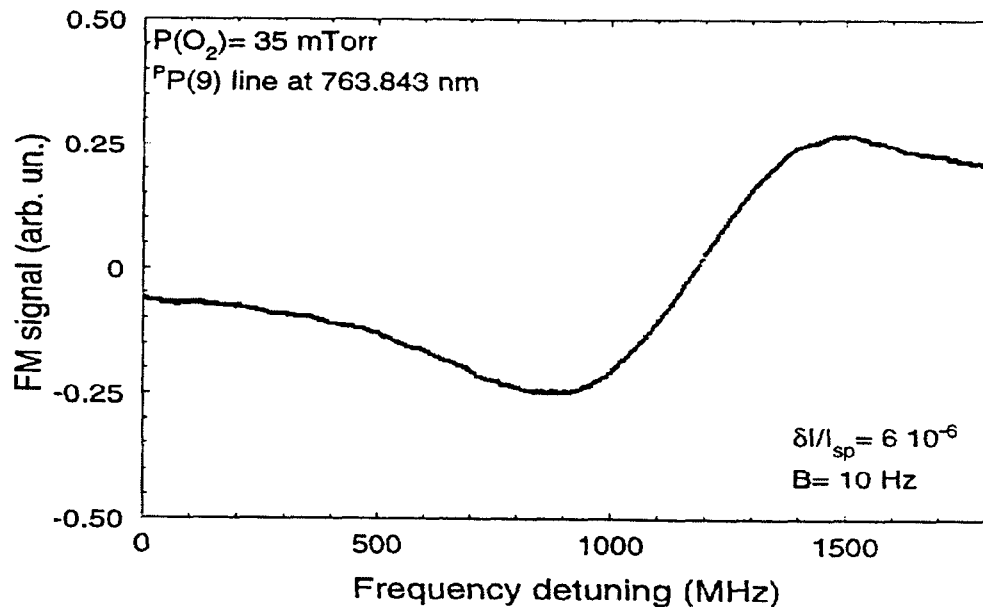

Fig. 2. Example of heterodyne detection of O_2 absorption at 763 nm in a high finesse cavity, corresponding to a single pass absorption of $6 \cdot 10^{-6}$.

The sensitivity of our spectrometer can be improved by at least 2 orders of magnitude, just by optimizing the NICE-OHMS detection method. The minimum detectable variation of the transmitted power was measured to be about $3 \cdot 10^{-5}$, which is about 200 times greater than the shot noise limit. The sensitivity is presently limited by the laser frequency noise that is converted by the cavity into amplitude noise. Hence, with a higher bandwidth on the laser current feedback loop, we should be able to increase the sensitivity and approach shot noise limited detection. In addition, we should be able to use a finesse greater than 10^4 to further decrease the minimum detectable oxygen pressure. This work is a contribution of the US government, and is not subject to copyright.

- [1] J. B. Paul, J. J. Scherer, A. O'Keefe, and R. J. Saykally, *Laser Focus World*, March 1997, p. 71.
- [2] D. Romanini, A. A. Kachanov, N. Sadeghi, and F. Stoeckel, *Chem. Phys. Lett.* 264, 316 (1997).
- [3] K. Nakagawa, T. Katsuda, A. S. Shelkovnikov, M. de Labachellerie, and M. Ohtsu, *Opt. Comm.* 107, 369 (1994).
- [4] M. de Labachellerie, K. Nakagawa, and M. Ohtsu, *Opt. Lett.* 19, 840 (1994).
- [5] Jun Ye, Long-Sheng Ma, and J. L. Hall, *Opt. Lett.* 21, 1000 (1996).