

A STUDY OF POINT-CONTACT JOSEPHSON JUNCTIONS FOR USE IN FREQUENCY SYNTHESIS

Allan S. Risley

Frequency & Time Standards Section
National Bureau of Standards
Boulder, CO 80302

ABSTRACT

A carefully controlled microwave experiment using point-contact Josephson junctions (PCJJ) is reported. The experiment measures the IF power, P_{IF} , generated in low-order frequency multiplication and mixing. Also measured is the number of induced steps produced by the microwave source. Four characteristics possessed by PCJJ's which gave the largest P_{IF} are described. These criteria are compared to those which were obtained in studies previously reported. There is good agreement with three of these criteria and the discrepancy with the fourth is discussed in detail. An operational procedure for fabricating a good PCJJ is described. The four most important potential high frequency limitations of a PCJJ are discussed with respect to the experimental results. This paper reports the use of a non-superconducting whisker plated with a superconductor.

INTRODUCTION

At the National Bureau of Standards we intend to phase-lock a far-infrared (FIR) laser to an X-band signal [1-3]. The aim is to be able to compare the frequency of a microwave source to that of a laser source, without losing cycle identification, at laser frequencies at least as high as 4.25 THz (70.5 μm). The large frequency multiplication orders, N , required indicate that the point-contact Josephson junction (PCJJ) is presently the best candidate for the multiplier and mixer. This paper discusses a microwave experiment aimed at improving the understanding and reliability of PCJJ's.

While the PCJJ has performed $N = 401$ (starting at X-band) [4] and $N = 825$ (starting at 1 GHz) [5] the reliability is inadequate for the present application. The practical problem is to learn how to make PCJJ's of sufficient quality and reliability. Junctions capable of giving a signal-to-noise ratio of at least 20 dB (in a 1 kHz bandwidth) for $N \approx 500$ is the goal.

The empirical results of NBS [6] and those of NPL [7] evolved four criteria which appear to characterize a good PCJJ for use at large N and specifically, where the upper frequency source is in the FIR. They are:

- (1) The critical current, I_0 , should be of the order of 250 μA . Critical currents lower than 50 μA and higher than 1 mA are outside the optimum range.
- (2) The product, $I_0 R$, (where R is the asymptotic resistance of the junction) should be of the order of 1 mV or greater.
- (3) The undriven I-V curve should show evidence of an "energy-gap" structure. [The dc component of the total current through the junction is I and that component of the voltage across it is V .]
- (4) The junction should show at least the first step in the I-V curve due to the laser drive, V_{laser} .

Presumably these empirical observations have an important relationship to the four major features that potentially limit the N value and maximum value of V_{laser} . These limitations are:

- (a) The spreading of the spectrum of the supercurrent as N increases [8].
- (b) High-frequency limitations of the Josephson effect due to the finite binding energy (i.e., the energy gap) of superconducting electron pairs [9].
- (c) Localized heating (due to the driving sources) which lowers I_0 [10].
- (d) The shunting of high-frequency currents due to the non-zero capacitance of the contact [11].

II. THE EXPERIMENT

In the experiment reported here, both simple mixing ($N = 1$), and third harmonic generation and mixing ($N = 3$) are studied. Two X-band sources are used in the first case, and an X-band and a K-band source are used in the second. The measured quantities are the intermediate frequency power, P_{IF} , and the voltage extent of the steps in the I-V curve produced by the microwave sources [7, 12, 13].

Experience has shown - but not satisfactorily explained - the importance of several parameters to the generation of a useful level of P_{IF} . These are: the maximum supercurrent, I_0 ; the asymptotic resistance, R ; the product, I_0R ; and the dc component of the voltage across the junction, V [4, 14-17]. Figure 1 defines these quantities.

A block diagram of the experimental set-up is given in figure 2. A few comments need to be made about some of the components: When the microwave switch is in positions 2 or 3, the junction is irradiated with both microwave sources and the system is set up for measuring P_{IF} . When the switch is in position 1, the junction is only irradiated by source #1 and the system is set up for measuring steps in the I-V curve.

The break between the waveguide and coaxial tees, and the 1.4 GHz coaxial filter, provide isolation such that the PCJJ is the only dc path that the bias box sees. This allows a known bias to be put on the junction and permits observation of the I-V curve. In addition to this function, the coaxial filter provides impedance matching at ν_{IF} (= 1.4 GHz) and rejection of the two microwave drives.

The Josephson junction mount fits directly into an ordinary storage dewar and is coaxial in structure. The whisker for the junction forms the extreme end of the center conductor, and the post forms a short at the end of the shield. The probe is inserted into the dewar with the junction open (i.e., the whisker not contacting the post) and the junction is closed only after the device comes to temperature. This allows the formation of contacts of sufficient sensitivity to be of interest.

III. EXPERIMENTAL RESULTS

Table I displays the two variables, P_{IF} and voltage-extent of steps, versus the four parameters. Rather than list the total number of observable microwave steps, I have listed that value of V at which the last observable step occurs. [Steps whose full height was as small as about 5 μA were observable. With reduction of the noise fed to the junction it is possible to study steps as small as a few nanoamperes [18]. In retrospect, it is unfortunate that it was not possible to resolve smaller steps because this might have permitted a more definitive interpretation of the data (see Section IV)]. The reason for this is that the self oscillation frequency is directly proportional to V

($\nu_J = 484 \text{ MHz}/\mu V$) and the appearance of a step is evidence of a zero-beat between ν_J and a harmonic of the drive signal. The original thought was that the extent of the steps in any given junction would be a measure of the high-frequency cut-off of that junction. This does not, however, seem to be the case.

There are several main features to be noted in this table:

- (1) If P_{IF} is greater than about 40 dB above the noise (in a 30 kHz bandwidth), steps are not observed. If P_{IF} is less than about 40 dB there are (usually) well defined steps.
- (2) Based on 21 contacts, P_{IF} greater than 50 dB above the noise correlates fairly well with $I_0R > 0.8 \text{ mV}$.
- (3) Based on 21 contacts, the absence of steps correlates rather well with $R > 2 \text{ ohms}$.
- (4) Based on 11 contacts, the voltage extent of the steps is not well correlated with I_0 .

Several other things are important to mention: At the time these data were taken, it was not possible to measure asymptotic resistance smaller than about 1 ohm. Thus, for many contacts, an accurate value of I_0R is not available and the corresponding I_0R element has been left blank.

An entry of N.M. in the P_{IF} column just means that P_{IF} was sufficiently low as not to be of interest, say, less than 35 dB.

If the initial or subsequent contacts of the whisker to the post are too violent, then the whisker will be blunted to the extent that a hysteretic I-V curve may result. An entry of Y in the hysteretic column means that this has happened. Further discussion of this subject is given at the end of this section.

The output, P_{IF} , does not necessarily have a single maximum versus V . In fact, for low levels of microwave drive, there will be very sharp peaks in P_{IF} versus V [8]. However, as the drive power is increased these several maxima broaden until finally there is but a single very broad maximum. [Actually, a maximum for positive V and one for negative.] Sometimes the maximum output that could be obtained occurred before these maxima coalesced. In any case, the last column lists that value of V corresponding to the set of P_{drive} and

V values that maximized P_{IF} . All the P_{IF} data of Table I (and the corresponding V's) were taken for $N=3$. For this case, P_{IF} is much less sensitive to $P_{K\text{-band}}$ than it is to $P_{X\text{-band}}$. To first-order, (for the $N = 3$ case) the optimum drive level (and this applies to both sources) is that which produces the maximum number of steps in the I-V curve. [It might be suggested that the smaller amount of P_{IF} that occurred with the low resistance junctions was just an impedance matching problem. This does not appear to be the case. A separate test indicates that the coaxial filter (fig. 2) can be adjusted to provide a good match to junctions ranging from 1 ohm to about 200 ohms. The filter was adjusted to maximize P_{IF} for each contact.]

The data of Table I were taken using six different whiskers. Three of the whiskers were made from solid niobium (Nb) wire of 0.005 cm (0.002 inches) diameter. One was made from solid Nb of 0.013 cm (0.005 inch) diameter. The other two were made from presharpended 0.005 cm (0.002 inch) diameter tungsten (W) wire which was subsequently plated with about 1 μm of Nb. To my knowledge, the present work represents the first use of plated PCJJ's for multiplication and mixing. The solid Nb whiskers were pointed by etching in pure hydrofluoric acid.

An examination of the table shows that for every case in which P_{IF} was greater than 40 dB above the noise, the whisker used was either the 0.013 cm (0.005 inch) diameter solid Nb or of the Nb-plated W type. The probable reason for this is the extreme difficulty in making a junction with a large I_{OR} product and with I_{O} of the order of 250 μA when using the 0.005 cm (0.002 inch) Nb whisker. The usual problem is that, as a person attempts to get an acceptably large I_{O} , the tip bends over and presumably such a large contact area results that the contact resistance becomes quite small and, at the same time, the supercurrent becomes excessively large.

A person intuitively feels that the I_{O} , R and capacitance values of a given junction will depend upon whisker preparation (e.g., sharpness of point, state of oxidation) and upon the procedure of contacting the whisker to the post. The junctions that are available for study in a given experiment will then depend upon these fabrication conditions and their variability. As the discussion in items c and d of section IV imply, important things go on in dimensions that are of the order of the wavelength of visible light and smaller.

If one understood the microscopic details of the contact he might be able to explain why some contacts work well and others don't. In the absence of this knowledge one can only hope for a procedure that has a high probability of producing high quality junctions. During the course of the present work such a procedure was developed and is described in the appendix.

IV. DISCUSSION

With section III as background, it is now appropriate to reexamine points 1-4 of section I.

The data of Table I correlate well with the idea that I_{O} needs to be of the order of 250 μA to produce good P_{IF} . It might be suggested that the I_{O} criterion and the I_{OR} criterion are not independent, that setting I_{O} to about 250 μA automatically gives a large I_{OR} product (The theoretical maximum I_{OR} for Nb is ≈ 2.4 mV). Table I seems to deny this because there are four contacts (#'s 16, 11, 20 and 7) that satisfy the I_{O} criterion but whose resistance is low. It appears, therefore, that an I_{OR} product of the order of 1 mV or greater is an independent and important criterion.

With respect to the energy-gap, four of the 21 contacts exhibit energy gap structure in their I-V curves. Figure 1 is, in fact, the I-V curve of contact 18. Each of these four contacts produced P_{IF} of 53 dB or greater. The largest other output was 51 dB produced by contact 15 and it exhibited a "pathological" I-V curve. It is important to note that the energy gap criterion correlates very well with the I_{O} and I_{OR} criteria discussed in the preceding paragraph.

Regarding steps in the I-V curve, the most surprising result is the strong negative correlation between the presence of microwave steps in the I-V curve and the level of P_{IF} . I do not have a quantitative explanation for this. There are, however, two qualitative things that can be said about factors that make steps difficult to see. First, noise will round the edges of the steps. The lower the frequency of the source which produces the steps, the closer spaced the steps will be. Close spacing in addition to noise rounding decreases the clarity of the steps. Second, for a given voltage spacing ΔV between steps, the current spacing between their centers, ΔI , will decrease with increasing resistance, i.e., $\Delta I = \Delta V/R$. If some mechanism prohibits the steps from being hysteretic, then their full height is limited to ΔI . Apparently such a mechanism exists because the only induced steps

(of which I am aware) that show hysteresis are associated with a closely coupled cavity resonance [19] which is not the case in the present work. Zimmerman and Sullivan have proposed that the absence of hysteresis in induced steps is due to noise which causes the junction to make a transition from the higher to the lower of the two possible energy states [20].

In the present experiment, steps were produced with the K-band source as well as the X-band. This was done by setting the attenuator for source #1 (the X-band source common to both the N=1 and N=3 experiments) to maximum. The switch was then put in position 3 and the junction irradiated with the K-band source. Any contact for which X-band steps could be produced also produced K-band steps. A contact that would not show X-band steps did not show K-band steps. The qualitative arguments given above probably bear on the unobservability of the steps but a quantitative explanation is lacking.

An important practical problem when a laser is used as the high frequency source is the difficulty in focusing upon the junction. In the past- when failing, after some effort at trying to get the PCJJ to respond to the laser - the quality of the junction has come into question. I presently believe that, if the I_0 , I_0R , and energy gap criteria are all met, the junction is vindicated.

Consider now, items a-d of section I:

Item a: Spectrum spreading

The present experiment typically showed a 10-13 db decrease in maximum P_{IF} between the N=1 and N=3 cases. The frequencies involved preclude this fall-off being due to energy gap or capacitance effects (items b and d). The experiment was performed such that the junction properties remained essentially unchanged between the N=1 and N=3 cases for any given contact. The measured fall-off should therefore be a legitimate measure of the spreading of the supercurrent with increased N value. In the absence of a quantitative theory (based on the constant-current model) of P_{IF} versus the several parameters discussed in this paper, the only further thing to be said is that the optimum "local oscillator" power in the N=1 case was from 6.5 to 11 dB less than that for the N=3 case.

Item b: Energy gap

For Nb, the binding energy (proportional to the energy gap) of an electron pair corresponds to a

frequency of about 720 GHz. Since the highest drive frequency in this experiment was 25.1 GHz, energy gap effects should not have been a limitation. The laser experiments which are planned [2] will involve frequencies from ~ 600 GHz to 4.25 THz (4250 GHz). Presumably the energy gap effect will then become important. Whether it will be possible to sort out the effects, a-d, one from another remains to be seen.

The present experiment does, however, have a potentially important bearing on this effect. The success in getting high quality junctions by plating Nb on W probably means that other superconducting materials would also work. Thus, for example, it may be possible to use Nb₃Sn or Nb₃Ge and essentially double the cutoff frequency due to this effect.

Item c: Heating

The analysis of Tinkham et al [10] on high frequency limitations due to heating, contains a parameter, P_0 . This is essentially the level of ac power, absorbed by the junction, at which heating effects become important. They estimate the value of P_0 to be 10 μ W. [This is based on adjusting the parameters of the theory to give a junction resistance (at large V) which is of the order of 10 ohms.] For the best contacts (17, 18, 21, 22), the local oscillator power at the top of the Josephson junction probe ranges from 36 μ W (#22) to 5 μ W (#18).

Since the characteristic impedance of the uniform part of the JJ probe is 50 ohms, the estimated values of absorbed power for #'s 22 and 18 are 0.16 μ W and 0.50 μ W respectively. I would, therefore, tentatively conclude that heating was not a significant limitation in this experiment. Estimating the drive level necessary to maximize P_{IF} for a laser frequency of 4.25 THz ($N \approx 460$), on the basis of the constant-voltage model [14], yields about 8 mW. It seems highly likely then, at the highest frequencies to which we intend to go, that heating will be a limitation.

Item d: Capacitance

Stewart has shown that when a junction is shunted by a sufficiently large capacitance, the resulting I-V curve will be hysteretic [21]. Others have realized this effect experimentally. A number of hysteretic I-V curves were obtained during the course of the present experiment. They are detrimental to obtaining good P_{IF} . Based on Stewart's work, an estimate has been made of the capacitance required to produce a hysteretic I-V curve typical of the present experiment. The result is 6.6 x

10^{-13} Farads. If it is assumed that this capacity results from a dielectric barrier between the post and the tip of the whisker (assuming $\epsilon = 25 \epsilon_0$ - the approximate dielectric constant of niobium oxide - and a barrier thickness of 10^{-9} m = 10 Å) then the cross sectional dimension of the effective parallel-plate capacitor would be 1.7 μ m.

Microscopic examination of whiskers which have produced hysteretic I-V curves shows them to be blunted and with a flattened area whose cross sectional dimension is of the order of 2 μ m. It is essential to note, however, that on several occasions, whiskers which have produced hysteretic I-V curves have been recontacted and the resulting I-V curve has not been hysteretic. In addition, junctions have been formed which never showed hysteresis and upon subsequent examination there was essentially no evidence of blunting. I tend to agree with Zimmerman that the usual contact dimension is usually significantly smaller than the radius of curvature of the tip [11]. Although the above calculation gives an upper limit to the capacitance, I know of no way to calculate a believable lower limit. As additional feeling for the numbers involved, if the cross sectional dimension were 0.5 μ m then the capacitance would be 5.5×10^{-14} Farads and the resulting cutoff frequency would be about 0.6 THz.

An additional comment about high frequency limitations: The maximum P_{IF} obtained for the N=3 case was $\approx 3 \times 10^{-10}$ watts. If P_{IF} were proportional to N^{-2} , then the output power at 4.25 THz would be about 1×10^{-14} watts. Previous experience with essentially this same condition (extrapolated from N = 401 to N = 461) yielded about 2×10^{-15} watts [4]. There has been some experimental evidence for a fall-off in output going as N^{-2} and an analytical prediction of such behavior [4,7]. The data of Blaney et al suggests, however, that the fall-off is more rapid if the laser frequency is above ~ 1 THz [9]. In sum: the spectrum spreading effect almost surely increases monotonically with increasing N value. For large N and large values of ν_{laser} , it is likely that heating will be important; energy gap effects probably will be important, and a significant degradation due to contact capacitance cannot be ruled out.

V. CONCLUSIONS

At microwave frequencies, there are three characteristics which, if simultaneously present, appear to assure a PCJJ which is a good frequency multiplier and

mixer. They are:

- (1) the critical current, I_0 , should be of the order of 250 μ A,
 - (2) the undriven I-V curve should display "energy gap" structure,
- and (3) the $I_0 R$ product should be of the order of 1 mV or greater.

The criterion of steps in the I-V curve, which is useful at laser frequencies, presents difficulties at microwave frequencies and this is discussed in the text.

The operational procedure - described in the appendix - of fabricating a PCJJ has a high probability of producing a good junction. In particular, the use of a tungsten whisker plated with a superconductor appears to be of significant importance in application.

There are four major effects that have potential for degrading multiplication and mixing performance at high frequencies. However, it is difficult to assess their absolute or even their relative effects at frequencies above about 1 THz. The present paper does, however, give quantitative information about spectrum spreading in going between the N=1 and N=3 cases at microwave frequencies.

ACKNOWLEDGEMENTS

Several people at NBS have been helpful in the work reported here. I am indebted to C.A. Hamilton for the use of his PCJJ mount and to L.O. Mullen for the fabrication of the Nb-plated tungsten whiskers. Discussions about Josephson junctions with J.E. Zimmerman were helpful. Useful comments on subject matter were made by R.M. Garvey, S.R. Stein and H. Hellwig.

APPENDIX

During the course of this work, a procedure has evolved which I have found to be very useful in producing a useable contact. In this procedure, one lead of an ordinary ohmmeter (multimeter) is connected to the post and the other to the whisker. The ohmmeter is set to the x100 scale and, if the contact is carefully made, the initial contact resistance - as indicated by the meter - is usually a few hundred ohms or more. The supercurrent at that time is almost always unacceptably small (less than 50 μ A). The next step is not to further increase the pressure upon the contact (which will usually blunt the point) but rather to change the scale of the ohmmeter to x10 and, perhaps, to x1. (On the

x100 scale I try and get a junction to stabilize at about 200 ohms. A 200 ohm resistor draws 2.3 mA on this scale. Subsequent switching of a PCJJ down to the x10 scale usually results in a resistance of 20 - 30 ohms. A 26 ohm resistor draws 19 mA on this scale. Switching to x1 usually results in a 3-5 ohm resistance. A 4.4 ohm resistor draws 140 mA.] This often will result in a supercurrent of about the right magnitude. If the I_0 is a little large or if the shape of the I-V curve needs improvement (in terms of the I_0 and energy gap criteria) then it is often possible to improve the junction by slightly backing off the pressure on the contact. Sometimes it is necessary to completely open the contact and begin the procedure again. In my experience this procedure has worked much more than half the time for the plated whiskers and the larger diameter whiskers. On the other hand, the often-used procedure of closing the contact with little or no bias across it has a high probability of damaging the tip beyond usefulness.

REFERENCES

- [1] S.R. Stein, Allan S. Risley, H. Van de Stadt and F. Strumia, "High Speed Frequency Modulation of Far Infrared Lasers using the Stark Effect," to be published in Applied Optics, July 1977.
- [2] S.R. Stein and H. Van de Stadt, "Electronic Tuning and Phase-Lock Techniques for Far Infrared Lasers," to be published in Proc. 31st Annual Symposium on Frequency Control, Atlantic City, NJ, June 1977.
- [3] S.R. Stein and J.P. Turneure, "Superconducting Cavity -Stabilized Oscillators with Improved Frequency Stability," Proc. IEEE 63, pp. 1249 (1975).
- [4] D.G. McDonald, A.S. Risley, J.D. Cupp, K.M. Evenson and J.R. Ashley, "Four hundredth order harmonic mixing of microwave and infrared laser radiation using a Josephson junction and a maser," Appl. Phys. Lett., Vol. 20, pp. 296-299, April 1972.
- [5] T.G. Blaney and D.J.E. Knight, "Direct 825th harmonic mixing of a 1 GHz source with an HCN laser in a Josephson junction," J. Phys. D: Appl. Phys., Vol. 7, pp. 1882-1886, 1974.
- [6] D.G. McDonald, A.S. Risley, J.D. Cupp and K.M. Evenson, "Harmonic mixing of microwave and far-infrared laser radiation using a Josephson junction," Appl. Phys. Lett., Vol. 18, pp. 182-164, February 1971.
- [7] T.G. Blaney and D.J.E. Knight, "Experiments using a superconducting point-contact harmonic mixer near 1 THz," J. Phys. D: Appl. Phys., Vol. 6, pp. 936-952, 1973.
- [8] A.S. Risley, E.G. Johnson, Jr. and C.A. Hamilton, "Analog computer studies of frequency multiplication and mixing with a Josephson junction," Proc. 1976 Applied Superconductivity Conference, Stanford University, August 1976, pp. 381-384.
- [9] T.G. Blaney, N.R. Cross and D.J.E. Knight, "Harmonic mixing and frequency measurement at 2.5 THz using Josephson junctions," (has been submitted to: J. Phys. D: Appl. Phys.).
- [10] M. Tinkham, M. Octavio and W.J. Skocopol, "Heating effects in high frequency metallic Josephson devices: voltage limit, bolometric mixing and noise," J. Appl. Phys., Vol. 48, pp. 1311-1320, March 1977.
- [11] J.E. Zimmerman, "A review of the properties and applications of superconducting point contacts," Proc. 1972 Applied Superconductivity Conference, Annapolis, MD, May 1972, IEEE, Inc. NY (1972).
- [12] C.A. Hamilton, "Analog simulation of a Josephson junction," Rev. Sci. Inst., Vol. 43, No. 3, pp. 445-447, March 1972.
- [13] V.E. Kose and D.B. Sullivan, "Influence of external noise on microwave-induced Josephson steps," J. Appl. Phys., Vol. 41, No. 1, pp. 169-174, January 1970.
- [14] C.C. Grimes and Sidney Shapiro, "Millimeter-wave mixing with Josephson junctions," Phys. Rev., Vol. 169, No. 2, pp. 397-406, May 1968.
- [15] T.G. Blaney, "Heterodyne laser radiation detection at 891 GHz using Josephson point contacts," Rev. Phys. Appl., Vol. 9, pp. 279-284, 1974.
- [16] T.G. Blaney and D.J.E. Knight, "Heterodyne reception at 891 GHz using a Josephson harmonic mixer and a microwave local oscillator," J. Phys. D: Appl. Phys., Vol. 7, pp. 1887-1893, 1974.
- [17] Y. Taur, J.H. Claassen and P.L. Richards, "Josephson junctions as heterodyne detectors," IEEE Trans. MTT, Vol. 22, No. 12, pp. 1005-1009, Dec. 1974.
- [18] Private communication, J.E. Zimmerman and D.B. Sullivan.
- [19] Arnold H. Silver and James E. Zimmerman, "Josephson weak-link devices," Applied Superconductivity, Vol. 1, Editor Vernon Newhouse (Academic Press, 1975).
- [20] J.E. Zimmerman and D.B. Sullivan, "High frequency limitations of the double-junction SQUID amplifier," to be published.
- [21] W.C. Stewart, "Current-voltage characteristics of Josephson junctions," Appl. Phys. Lett., Vol. 12, No. 8, April 1968.

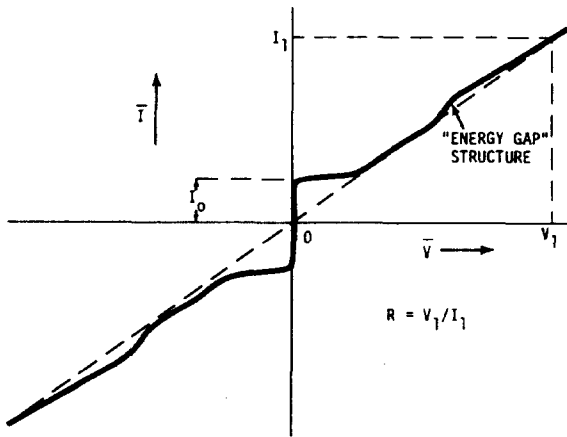

FIGURE 1. The total dc current, \bar{I} , through the PCJJ is plotted versus the dc voltage, \bar{V} , across it. For large values of \bar{V} (say, V_1) \bar{I} asymptotically approaches the dashed line.

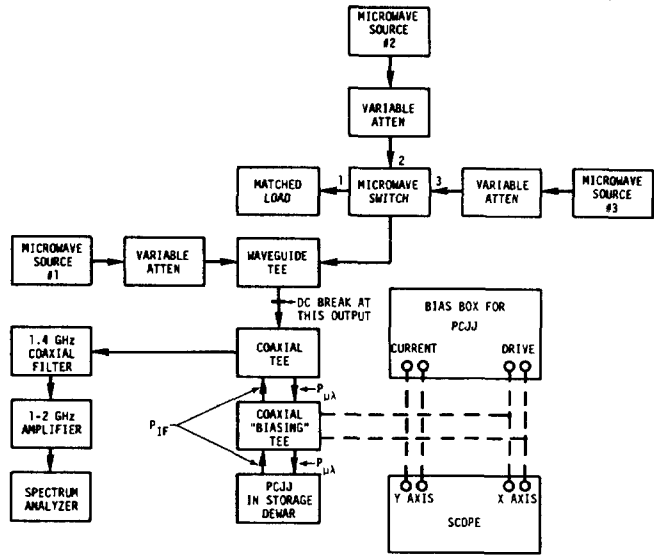

FIGURE 2. Block diagram of experimental set-up.

EXTENT OF STEPS (μV)	$2 I_0$ (μA)	R (ohms)	$I_0 R$ (mV)	CONTACT #	P_{IF} FOR $N = 3$ (dB ABOVE NOISE IN 30 kHz B.W.)	HYSTERETIC ?	\bar{V} FOR MAX P_{IF} (μV)	TYPE OF WHISKER
1,000	580	N.M. (NOT MEASURED)	--	10	N.M.	Y		†
800	3,850	< 1	--	23	31	Y	10	‡
> 700	680	2.8	0.95	16	41		30	•
~ 700	1,050	< 1	--	3	N.M.			†
700	800	< 1	--	11	N.M.	Y		†
700	1,500	< 1	--	14	N.M.			*
600	1,400	< 1	--	12	N.M.	Y		†
~ 500	180	< 1	--	2	N.M.			†
450	530	~ 1	~ 0.5	20	34		10	•
420	1,600	< 1	--	8	35		4	†
180	520	< 1	--	7	35		45	†
NOT VISIBLE	480	~ 9	2.2	21	54		500	‡
	300	8.8	1.3	18	59		600	*
	300	8.4	1.3	19	41	Y	200	*
	150	~ 7	0.53	5	N.M.	Y		†
	560	6	~ 1.7	22	53		100	‡
	200	4.5	0.45	1	40	Y	550 & 90	†
	400	4.2	0.84	17	57		500	*
	320	4.0	0.64	24	47		250	‡
	140	2.0	0.14	4	N.M.			†
	50	0.9	0.045	6	25		10	†
	1,800	< 1	--	15	51		N.M.	*

† = 0.002" SOLID Nb

‡ = 0.005" SOLID Nb

• = 0.002" Nb-PLATED W