

RECENT IMPROVEMENTS MADE TO THE NIST FREQUENCY MEASUREMENT SERVICE

Michael A. Lombardi and Lisa M. Nelson

NIST

Time and Frequency Division

325 Broadway

Boulder, CO 80303

Voice: (303) 497-3212 or (303) 497-3378

FAX: (303) 497-3228

e-mail: lombardi@bldrdoc.gov

ABSTRACT

The NIST Frequency Measurement Service (FMS) assists calibration labs who make NIST-traceable frequency calibrations at high accuracy levels. The service has recently been redesigned to provide better data and more features to NIST calibration customers. Each customer receives a frequency measurement system which they install in their laboratory. The system calibrates 5 oscillators at once, uses GPS as a reference frequency (it formerly used LORAN-C), offers < 40-picosecond single shot measurement resolution, and measures short term stability using the Allan Variance. Each customer receives monthly certification that their frequency calibrations are traceable to NIST. The FMS can help laboratories gain accreditation in the frequency calibration field.

INTRODUCTION

The NIST Frequency Measurement Service (FMS) provides each customer with a frequency measurement system that they install in their lab. This system includes the hardware, software, and documentation needed to automatically measure and calibrate from 1 to 5 frequency standards at once. NIST provides training and phone support, and validates each customer's data through a modem hookup. All parts that fail are replaced using an overnight delivery service. In addition, each lab receives a monthly certificate that documents traceability to NIST.

The FMS began operation in 1984¹, but was recently redesigned to incorporate the latest developments in the frequency measurement field. This paper provides an overview of frequency calibrations and discusses the improvements made to each aspect of the FMS.

AN OVERVIEW OF FREQUENCY CALIBRATIONS

According to International Standards Organization (ISO) guidelines, a calibration is:

*A set of operations that establish, under specified conditions, the relationship between values of quantities indicated by a measuring instrument or measuring system, or values represented by a material measure or a reference material, and the corresponding value realized by standards.*²

In other words, a calibration is a comparison between the device being calibrated and a reference. In the field of frequency calibrations, the devices being calibrated are oscillators

based on *quartz*, *rubidium*, or *cesium* frequency standards. The *reference* is another frequency standard of higher quality. As a general rule, the reference should perform significantly better (usually one order of magnitude) than the device being calibrated.

The comparison technique depends upon the type of *measurement system* in use. There are numerous ways to design a measurement system, but all systems should be able to state how accurately an oscillator produces its *nameplate frequency*. The nameplate frequency is the frequency labeled on the oscillator output. For example, an oscillator output labeled "5 MHz" is supposed to produce a 5-MHz frequency. The calibration should state how close the actual frequency is to 5 MHz.

The difference between the nameplate frequency and the actual oscillator output frequency is called the *frequency offset* and is a measure of the frequency *accuracy* of the device being calibrated. For the purposes of calibration, the frequency offset is normalized to make it independent of the nameplate frequency. For example, if an oscillator is accurate to 1×10^{-9} , then its frequency is in error by 1 part in 1 billion parts. This holds true if the nameplate frequency is 1 MHz, 5 MHz, 10 MHz, or something else. Of course, if the nameplate frequency is known, the frequency offset can easily be converted to Hz.

Calibration laboratories normally specify a required level of accuracy that the device being calibrated must meet or exceed. A frequency standard has been successfully calibrated when it meets its required level of accuracy. In some cases, an adjustment to the oscillator must be made before the calibration is successful. In other cases (if the oscillator is broken, for example) it may be unable to meet the accuracy requirement. In this case the oscillator has failed calibration and must be repaired or removed from service.

All frequency calibrations should be *traceable*. The ISO definition for *traceability* is:

*The property of the result of a measurement or the value of a standard whereby it can be related to stated references, usually national or international standards, through an unbroken chain of comparisons all having stated uncertainties.*³

In the United States, the "unbroken chain of comparisons" should trace back to NIST. In some fields of calibration, traceability is established either by sending the standard to NIST or another site for calibration, or by sending a set of reference materials (like a set of weights used for mass calibrations) out to the user. Neither method is practical in the frequency calibration world. Frequency standards are sensitive to being turned on and off. If a standard is calibrated and then turned off, the calibration may be invalid when the oscillator is turned back on. In addition, the vibrations and temperature changes encountered during shipment can also change the results. For these reasons, laboratories should make the calibrations on-site.

Fortunately, there is an easy way to deliver a traceable frequency reference to a calibration laboratory. A number of traceable radio signals can be used as a reference (WWV, WWVB, LORAN-C, and GPS, for example)⁴. WWV and WWVB are operated by NIST, and LORAN-C and GPS are monitored by NIST. In both cases, the "unbroken chain

of comparison" is kept intact. Each signal delivers traceability at a certain (known) accuracy. The signal used depends upon the level of accuracy required.

The ability to use radio signals is a tremendous advantage. The radio signals serve as a *transfer standard* that delivers a frequency reference from the national standard to the user's site. A transfer standard allows traceable calibrations to be made simultaneously at a number of sites as long as each site is equipped with a radio receiver. It also eliminates the difficult and undesirable practice of moving frequency standards from one place to another.

Once a traceable transfer standard is in place, the next step is developing the technical procedure used to make the calibration. This procedure is called the *calibration method*. The method should be defined and documented by the laboratory, and ideally; a measurement system should be built which automates the procedure. ISO/IEC Guide 25, *General Requirements for the Competence of Calibration and Testing Laboratories*, states:

The laboratory shall use appropriate methods and procedures for all calibrations and tests and related activities within its responsibility (including sampling, handling, transport and storage, preparation of items, estimation of uncertainty of measurement, and analysis of calibration and/or test data). They shall be consistent with the accuracy required, and with any standard specifications relevant to the calibrations or test concerned.

In addition, Guide 25 states:

*The laboratory shall, wherever possible, select methods that have been published in international or national standards, those published by reputable technical organizations or in relevant scientific texts or journals.*⁵

Designing a measurement system is complex and can be a problem for calibration labs. NIST started the FMS to help solve this problem. FMS customers receive a turn-key measurement system that automates the calibration process using a well-established and documented method. By subscribing to the FMS, laboratories solve their frequency calibration problem without incurring the labor and equipment costs associated with designing their own system. In addition, NIST continually strives to keep the design of the measurement system updated, by incorporating the latest technology in the field. This is discussed in the next section.

IMPROVEMENTS TO THE SYSTEM DESIGN

NIST has traditionally designed frequency measurement systems by combining commercially available hardware with hardware, software, and measurement techniques developed at NIST.⁶ The new measurement system continues in this tradition.

The new measurement system is named the Frequency Measurement and Analysis System (FMAS). The FMAS is rack-mounted and controlled by an industry-standard 486 computer system. Software developed at NIST controls all aspects of the measurement process. It makes measurements, and stores and graphs them automatically. It backs up the

data automatically (on tape) every 10 days. A block diagram of the FMAS is shown in Figure 1.

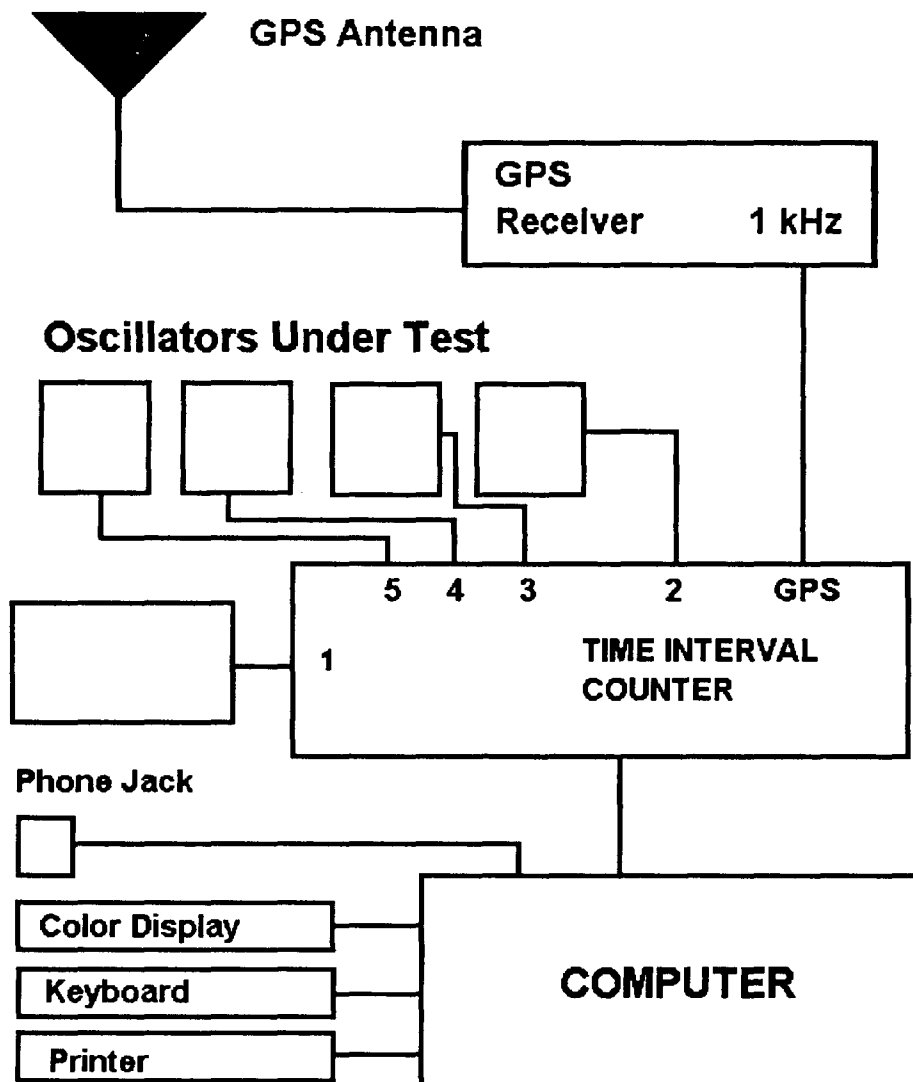

Figure 1 - Block Diagram of the NIST Frequency Measurement and Analysis System

Recent advancements to the FMS have improved its ease of use, the measurement resolution, and the quality of the transfer standard. In addition, new features have been added. Let's look at each of these improvements in turn.

EASE OF USE

The FMAS was designed to make it easy to calibrate oscillators. How easy? You simply connect from 1 to 5 oscillators to the system and type in the name of each oscillator from the keyboard. You'll see a screen similar to the one shown in Figure 2. The screen is a bar graph that shows the accuracy of each oscillator connected to the FMAS.

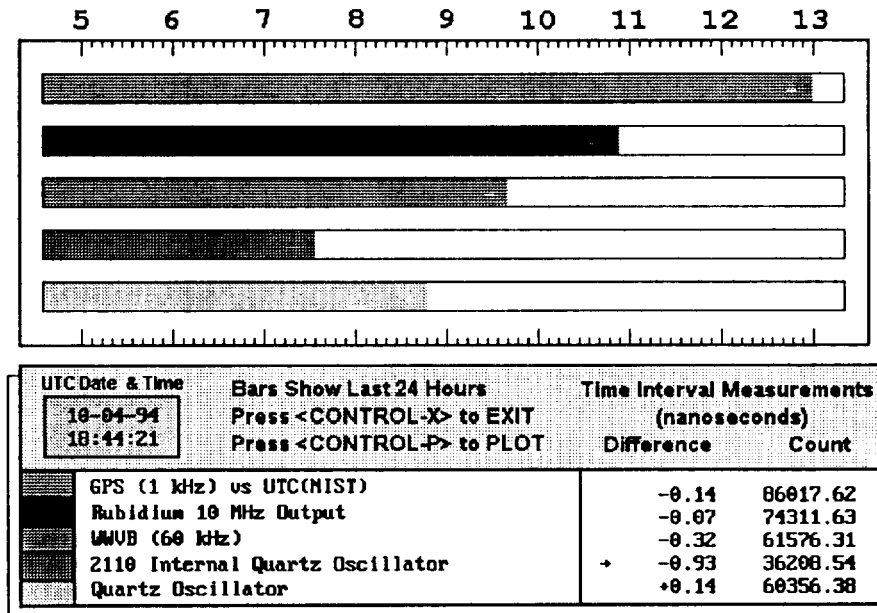

Figure 2 - The NIST FMAS Measurement Screen

By looking at the graph, you can quickly tell if the oscillator meets its calibration requirement. The numbers above the bar show the oscillator's performance over the past 24 hours. For example, if a bar extends to the number 9, it represents a frequency offset of 1×10^{-9} . The longer the bar, the better the performance of the oscillator. If the bar extends all the way to the right, the frequency offset is 1×10^{-13} or better.

Each bar is color coded, and a different color is used for each of the five channels. Often, all you need to do is periodically look at the length of the bar to see if things are working properly. For example, you may need to distribute a 5 MHz signal throughout an entire facility and maintain this signal at an accuracy of 1×10^{-9} or better. If the bar extends past the number 9, you'll know that the distributed signal meets its requirements.

Of course, you may need more detail than the bar graph provides. For this reason, the FMAS automatically graphs each oscillator's performance every 24 hours. Since 1 to 5 oscillators can be calibrated, from 1 to 5 graphs are printed each day. These graphs can also be printed at any time by simply pressing a key. The graphs are printed on regular 8.5 x 11 inch paper (one graph per page). A sample graph is shown in Figure 3.

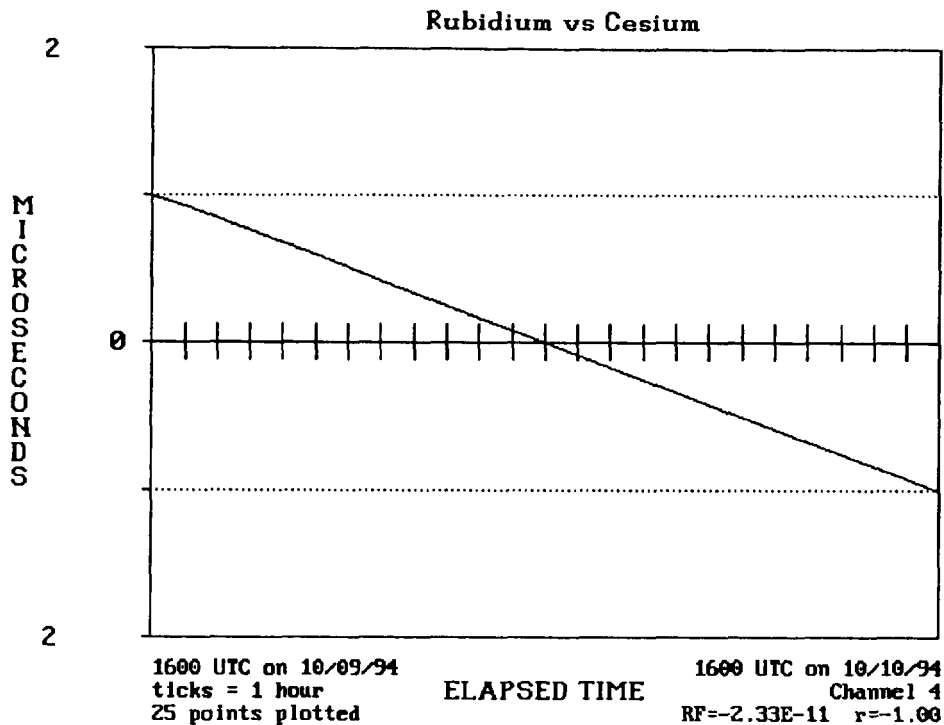

Figure 3 - A Sample Graph produced by the FMAS

The graph in Figure 3 shows the performance of an oscillator with a frequency offset (accuracy) of -2.33×10^{-11} . In this case, the oscillator being calibrated is a rubidium, and the reference frequency is a cesium.

All data recorded by the FMAS is automatically saved and can be retrieved at any time. Users aren't limited to producing 24-hour graphs like the one in Figure 3. The FMAS can produce graphs for intervals ranging from 2 seconds to 3600 hours (150 days).

IMPROVED MEASUREMENT RESOLUTION

The FMAS measures frequency using the time-interval method. It includes a time-interval counter (developed at NIST) with a single-shot resolution of less than 40 picoseconds and a maximum sampling rate of 2 kHz.⁷ Previous versions of the system used a counter with 10 nanosecond resolution. Because of this huge improvement in resolution, the new system can measure oscillator performance much faster than the old system.

The time interval counter has built-in multiplexers that allow it to measure and calibrate up to 5 oscillators simultaneously. It also includes built-in divider circuitry that allows it to accept a 1, 5, or 10 MHz input on each of the 5 channels. This allows the FMAS to accept the output of most quartz and atomic oscillators.

IMPROVED TRANSFER STANDARD

The FMAS uses signals from the Global Positioning System (GPS) as a transfer standard. Previous versions of the system used LORAN-C, but GPS has several advantages. The signal is easier to receive, requires a much smaller antenna, and offers slightly better performance. GPS also provides time-of-day information to the FMAS, whereas LORAN-C lacked a time code. Perhaps the biggest advantage of GPS over LORAN-C is its coverage area. LORAN-C is a ground-based system, and users must typically be within 1600 kilometers (1000 miles) of a transmitter site to receive the signal. In many parts of the world, LORAN-C is not usable. For example, no transmitters are located in the Southern Hemisphere. By contrast, GPS can be received anywhere on earth.

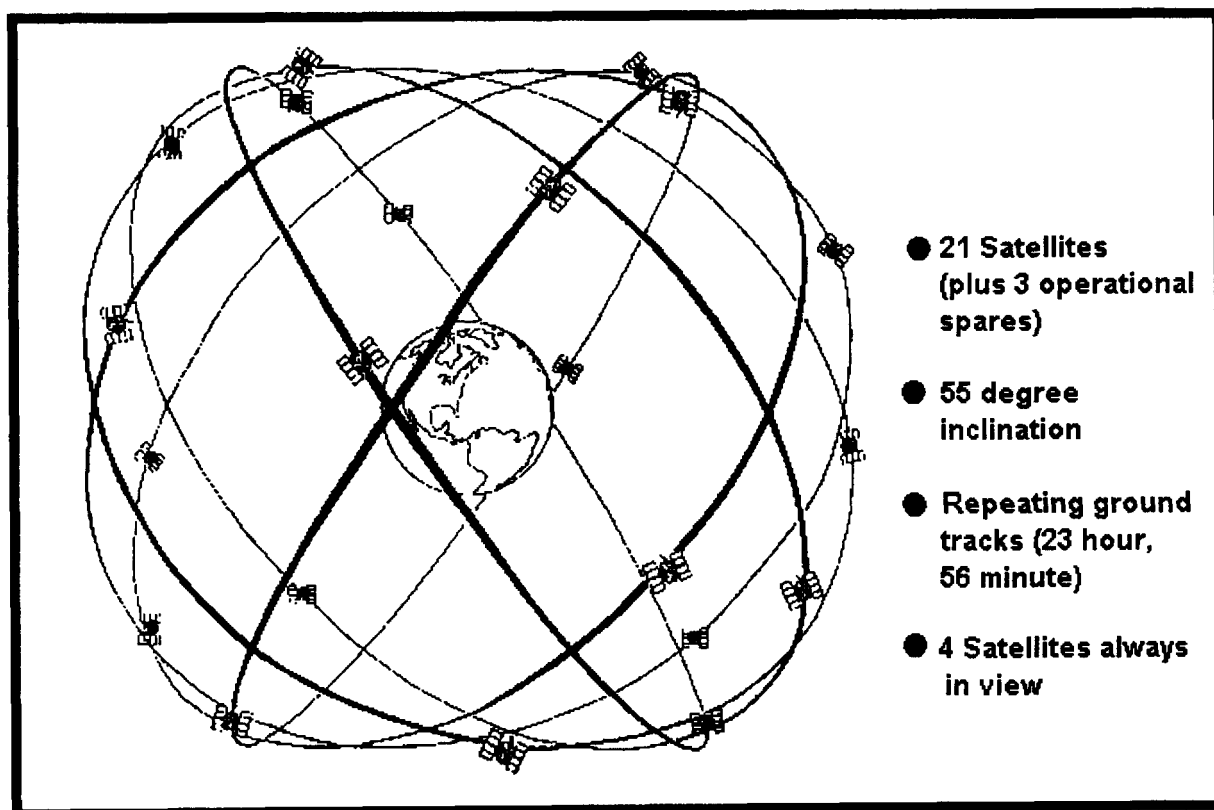

Figure 4 - The GPS Constellation

GPS was developed by the U.S. Department of Defense (DoD) to provide continuous, worldwide positioning and navigation data to U.S. military forces around the globe. GPS is based on a constellation of 21 satellites (plus 3 in-orbit spares) orbiting the Earth in six fixed planes that are inclined 55° from the equator. Each satellite is 20,200 kilometers (10,500 miles) above the earth and has a 12 sidereal hour orbital period, which means a satellite will pass over the same place in its revolution 4 minutes earlier each day. Figure 4 shows the GPS system constellation.

Each satellite has 4 atomic oscillators on board that allow the satellites to keep accurate and stable time. These oscillators are referenced to the United States Naval Observatory (USNO) and are traceable to NIST.⁸ Their frequency accuracy over a 24-hour period is 5×10^{-13} . This makes GPS an excellent reference for frequency calibrations. Frequency information is continuously broadcast by each satellite in two signals: a coarse acquisition (C/A) code for worldwide civilian use, and a precision (P) code signal for U.S. military use only. The C/A code is a spread-spectrum signal broadcast at an L-band frequency of 1575.42 MHz. The P code is a spread-spectrum signal transmitted on two L-band frequencies (1575.42 MHz and 1227.6 MHz). The FMAS uses the C/A code signal to derive accurate frequency. The C/A code is a pseudo-random sequence that is generated by both the satellite and the receiver and repeats about once per millisecond.⁹

Measuring this distance between 4 of the satellites and the receiver gives a 3-dimensional coordinate for the location of the receiver. Once the receiver location is known, the path delay can be computed, and the time between the satellites and receiver can be synchronized. The receiver then uses this information to update the list of satellites that are in view and to keep the positioning data correct. Monitoring the fourth satellite provides the necessary time error values between the satellites to allow the receiver to correct its time output. Once the GPS timing signal is acquired the receiver synchronizes its 1 Hz and 1 kHz outputs to Coordinated Universal Time (UTC).

The receiver automatically selects and tracks the satellites that are currently in view. Normally, at least 4 satellites will be in view, but once a position has been computed, the receiver is capable of synchronization with just 1 satellite. If 3 or more satellites are visible, more precise measurements can be made using timing corrections made by the receiver.

The GPS receiver used by the FMAS is rack-mounted and uses a small antenna that must be mounted outdoors where it has a clear view of the sky. When the FMAS is first installed, it takes about 20 minutes for the GPS receiver to acquire the signal. During this time, the receiver searches the sky for satellites and computes its position. This process will not have to be repeated unless the system is moved. If the receiver is turned off, it should acquire the signal in less than one minute when turned back on. Once the signal is acquired, the receiver synchronizes its frequency outputs (1 kHz and 1 Hz) to UTC. As shown in Figure 1, the FMAS uses the 1 kHz output as its reference frequency. The 1 Hz output is available for applications requiring an on-time pulse.

To illustrate the performance capability of the FMAS, Figure 5 shows a 1-week comparison between GPS and a cesium oscillator. The frequency offset of the cesium (accuracy) is 5.46×10^{-13} .

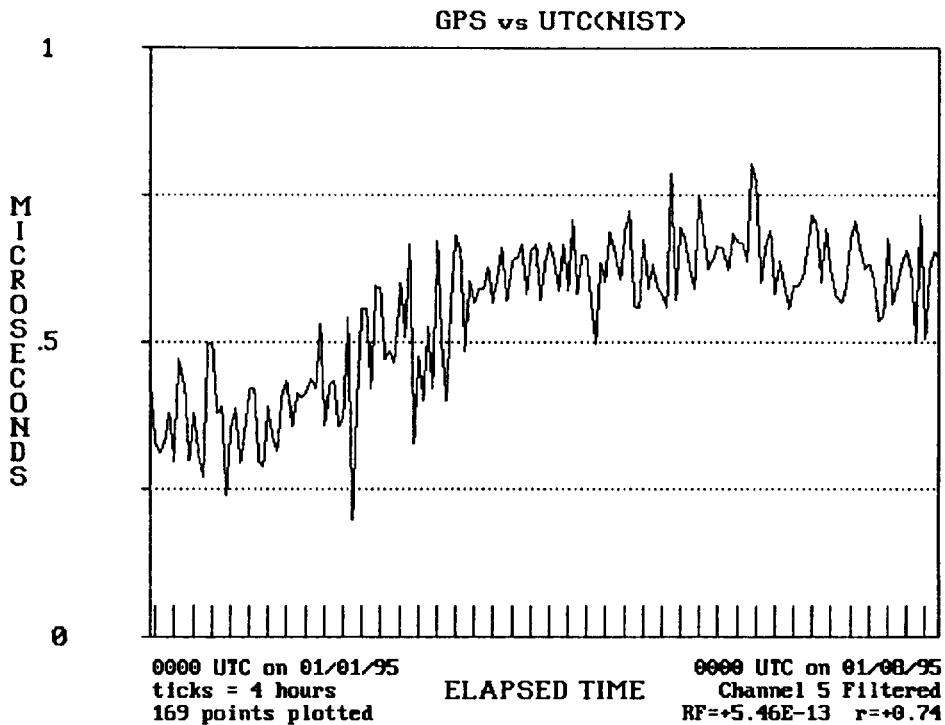

Figure 5 - GPS data compared to UTC(NIST) for a 1-week period

NEW FEATURES

The FMAS has always been useful as a calibration tool. Recently, features have been added that make it useful as a *characterization* tool. Characterization is more involved than calibration. It involves measuring both the accuracy and *stability* of an oscillator, and being able to state both characteristics quantitatively. For example, if we can state that an oscillator is accurate to 1.32×10^{-8} and has a stability of 1.34×10^{-12} at 1000 seconds, the oscillator has been *characterized* for that interval. Of course, the exact tests required to complete an oscillator characterization must be determined by the laboratory.

Stability is a description of the frequency change of an oscillator that occurs over time. Short-term stability usually refers to changes over intervals of less than 100 seconds. Long-term stability can refer to measurement intervals greater than 100 seconds, but usually refers to periods longer than 1 day. A statistical test used to measure stability is the *Allan Variance (AVAR)*, also called the *two-sample* or *pair* variance.¹⁰ AVAR graphs show the stability of the oscillator output with the drift removed. A sample AVAR graph is shown in Figure 6. The graph shows the stability of a rubidium oscillator over a 5-minute period.

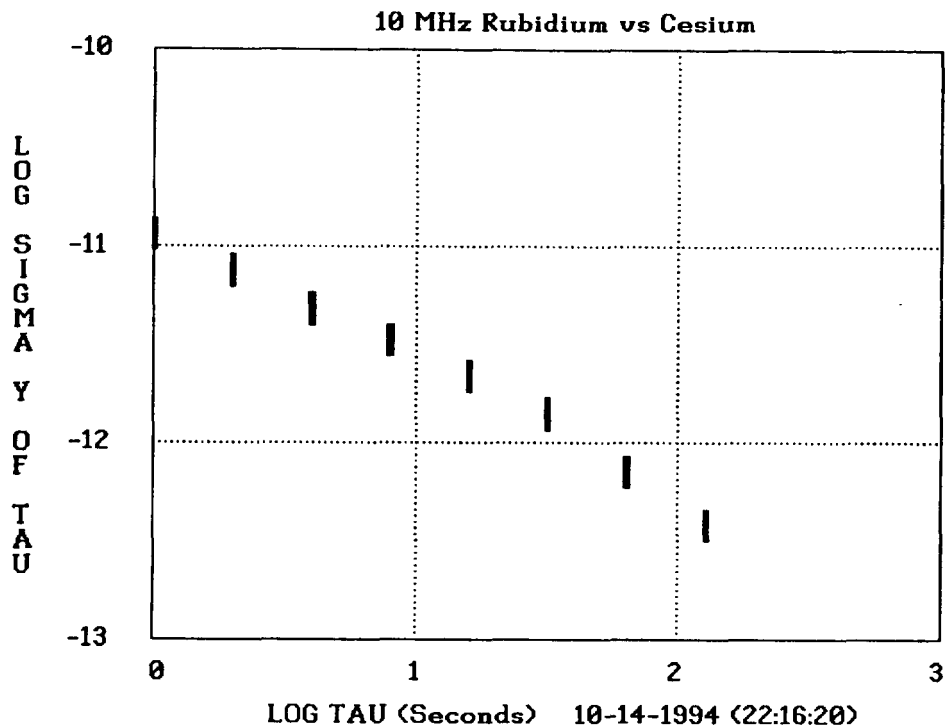

Figure 6 - Stability Plot (AVAR) of Rubidium over 5-Minute Period

AVAR plots use a logarithmic scale. The values along the x-axis (called *tau* values) represent the length of the averaging period in seconds. Each division represents an averaging period 10 times longer than the previous division. For example, a tau value of 2 represents an averaging period of 100 seconds (10^2). A tau value of 3 represents an averaging period of 1000 seconds (10^3).

The values along the y-axis represent the result of the measurement. A value of -10 means that the oscillator has a stability of 1×10^{-10} . This value should not be confused with the accuracy. For example, an oscillator off in frequency by 1×10^{-8} may reach a stability of 1×10^{-12} in 1000 seconds. This means that, although the oscillator is not very accurate, it is very stable. Stability is an inherent quality of the oscillator. Adjusting the oscillator might improve the accuracy, but it won't change the stability.

A typical AVAR plot (like the one in Figure 6) shows the stability values improving as the measurement period increases in length. This continues until the oscillator reaches its *noise floor*, at which point the stability values will level out and then eventually start to get worse. Most oscillators reach their noise floors at a tau value of around 3. The FMAS is capable of measuring stability at a level of 1×10^{-14} at a tau value of 3. This is good enough to measure nearly any oscillator.

The new FMAS also has increased data capacity, improved graphics, and software that displays the current status of the GPS signal and shows which satellites are currently in use. Table 1 lists the measurement specifications of the new FMAS.

Number of Measurement Channels	5
Input Frequencies Accepted by the System	1, 5, and 10 MHz
Minimum Measurement Interval	2 seconds
Maximum Measurement Interval	3600 hours
Averaging Period (long term)	1 hour
Averaging Period (short term)	1 second
Single Shot Measurement Resolution	< 40 picoseconds
Accuracy using GPS (24 hours)	5×10^{-13}
Stability (AVAR) after 1000 second self-test	1×10^{-14}

Table 1 - FMS Measurement Specifications

NIST SUPPORT

NIST completely supports each customer of the NIST Frequency Measurement Service. When parts fail, they are replaced immediately (usually overnight). In addition, each FMS includes remote communications software. This allows NIST to run each system from Boulder through the phone lines. NIST can diagnose and troubleshoot problems with the system, and view and graph the measurement data. When necessary, NIST can perform maintenance on the computer, like optimizing the hard drive, recovering a damaged file, or installing new software.

NIST downloads the daily relative frequency values from each customer and sends them a monthly report which certifies that their data is traceable. If the data is poor, NIST will investigate the problem (a poor GPS signal or bad oscillator, for example) and help the customer correct it. Technical support is provided by telephone Monday through Friday, during normal working hours (8 to 5, Mountain Time).

LABORATORY ACCREDITATION

The FMS/FMS standardizes the way that a laboratory performs frequency calibrations. All customers record data in the same way, using the same measurement techniques developed by NIST. These techniques are well documented and widely accepted in the field of metrology.

Over the past few years, it has become increasingly important for calibration laboratories to become accredited and for their companies to obtain ISO-9000 registration. Some companies now view laboratory accreditation and ISO-9000 registration as a prerequisite to doing business. The FMS/FMS can help these laboratories obtain accreditation since it conforms to the guidelines published by the National Voluntary Laboratory Accreditation Program (NVLAP), which became operational in May 1994.

NVLAP is a NIST-operated program that assesses the technical competence of calibration labs, and grants accreditation to those who qualify.

The NVLAP guidelines are based on ISO Guide 25, ISO-9002, and the ANSI/NCSL Z540-1 military standard. They are outlined in the *NVLAP Calibration Laboratories Technical Guide (NIST Handbook 150-2)*.¹¹ This document includes technical descriptions of how calibrations should be made.

NVLAP can accredit laboratories in eight different areas of calibration (called *fields*). Each field is divided into more detailed areas called *parameters*. For example, frequency calibration is a parameter in the time and frequency field. FMS customers can easily obtain NVLAP accreditation for frequency calibration if they choose to do so.

REFERENCES

- 1 George Kamas and Michael A. Lombardi, Michael A., "A New System for Measuring Frequency", *NCSL Conference Proceedings*, 1985, pp. 224-231.
- 2 International Organization for Standardization (ISO), *International Vocabulary of Basic and General Terms in Metrology (VIM)*, 1993, p. 48.
- 3 VIM, p. 47.
- 4 George Kamas and Michael A. Lombardi, *Time and Frequency User's Manual*, NIST Special Publication 559, 1990.
- 5 ISO/IEC Guide 25, *General Requirements for the Competence of Calibration and Testing Laboratories*, Int. Org. for Standardization (ISO), 1990.
- 6 Michael A. Lombardi, "The Design Philosophy of the NIST Frequency Measurement Service", *NCSL Conference Proceedings*, 1991, pp. 277-287.
- 7 Victor S. Zhang, Dick D. Davis, and Michael A. Lombardi, "High Resolution Time Interval Counter", *Precise Time and Time Interval Conf. (PTTI)*, 1994.
- 8 D. Bodson, R. T. Adair, and M. D. Meister, "Time and Frequency Information in Telecommunication Systems Standardized by Federal Standard 1002A", *Proc. of the IEEE*, vol. 79, no. 7, pp. 1077-1079, July 1991.
- 9 B. Hoffmann-Wellenhof, H. Lichtenegger, and J. Collins, *GPS Theory and Practice*, Springer-Verlag, 2nd edition, 1993.
- 10 D. B. Sullivan, D. W. Allan, D. A. Howe, and F. L. Walls, editors, *Characterization of Clocks and Oscillators*, NIST Technical Note 1337, 1990.
- 11 Jon M. Crickenberger, editor, *NVLAP Calibration Laboratories Technical Guide*, NIST Handbook 150-2, 1994.